

INSTRUCTION  
MANUAL

electronic typewriter

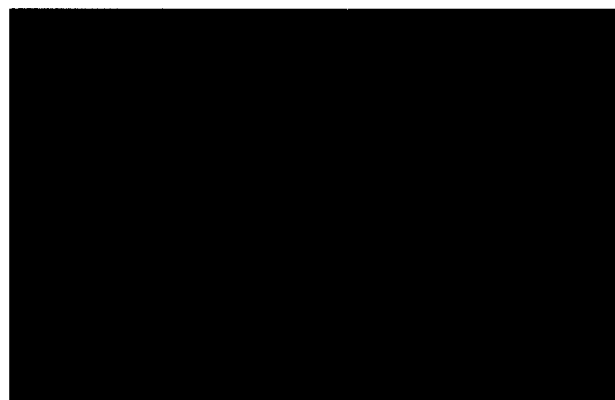

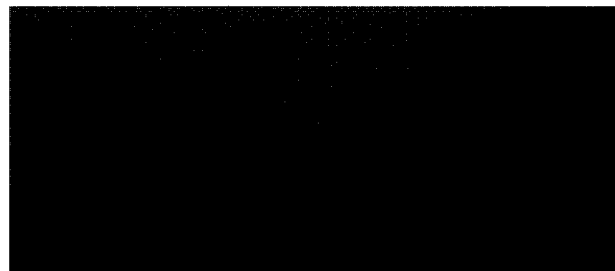
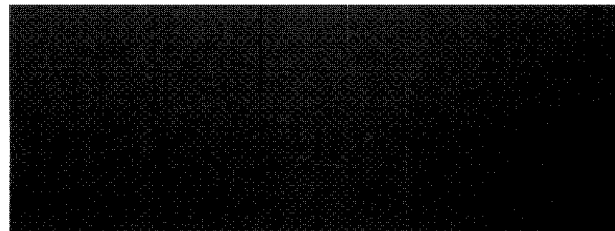
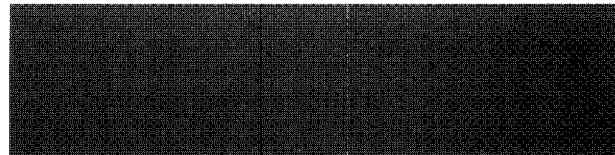
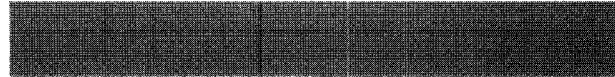

**Your new Electronic Typewriter increases your typing efficiency through use of the most advanced technology. Some of the many outstanding features of your typewriter are:**

- **17.0 inch paper capacity**
- **Easy-to-change 100-character drop-in printwheel**
- **Pitch selector : 10, 12 and 15 characters per inch**
- **Five-line correction memory (250 characters max.)**
- **Full electronic tabulator (30 positions resettable)**
- **Copy control (three lever positions)**
- **Automatic underlining (full and word by word)**
- **Automatic centering**
- **Automatic carrier return**
- **Automatic relocation**
- **Decimal tabulation**
- **Express backspace**
- **Micro up/micro down**
- **Caps lock**
- **Bold typing**
- **Format (margin and tab) memory**
- **Optional parallel interface (printer function)**

**This manual describes your typewriter's functions, operating controls, these procedures, and replacement of its accessories. Thorough study of instructions will facilitate and maximize the efficient use of your new electronic typewriter.**

# TABLE OF CONTENTS

<b>RULES FOR SAFE OPERATION .....</b>	<b>3</b>
<b>PART NAMES AND FUNCTIONS .....</b>	<b>4</b>
<b>BASIC OPERATIONS.....</b>	<b>6</b>
1. HOW TO START TYPING.....	6
2. MARGINS.....	9
3. TABS.....	11
4. CORRECTIONS.....	12
<b>SPECIAL FUNCTIONS .....</b>	<b>14</b>
1. DECIMAL TABULATION.....	14
2. AUTOMATIC CENTERING.....	15
3. AUTOMATIC CARRIER RETURN.....	16
4. REQUIRED HYPHEN AND REQUIRED SPACE.....	16
5. AUTOMATIC PARAGRAPH INDENTATION.....	17
6. SECOND KEYBOARD (SPECIAL CHARACTER SET).....	17
7. CAPS LOCK .....	18
8. MICRO UP/MICRO DOWN .....	18
9. AUTOMATIC UNDERLINING.....	19
10. BOLD TYPING .....	20
11. FRAMING.....	20
12. FORMAT (MARGIN AND TAB) MEMORY .....	21
<b>HOW TO CHANGE ACCESSORIES .....</b>	<b>22</b>
1. RIBBON CASSETTE .....	22
2. CORRECTION TAPE.....	23
3. PRINTWHEEL.....	24
<b>SUPPLIES.....</b>	<b>25</b>
<b>MAINTENANCE AND SERVICE .....</b>	<b>25</b>
1. CLEANING .....	25
2. SERVICE .....	25
3. REMOVING AND ASSEMBLING THE PLATEN.....	26
<b>OPTIONAL PARALLEL INTERFACE/HOW TO USE AS A PRINTER.....</b>	<b>27</b>
1. CONNECTION TO YOUR COMPUTER.....	27
2. SET-UP MODES, PUT ON-LINE.....	27
3. CHARACTER TABLE AND CONTROL CODE .....	29
4. SPECIFICATIONS.....	35
5. CONNECTOR PIN ASSIGNMENT .....	35
6. PARALLEL INTERFACE TIMING DIAGRAM .....	36

---

# **RULES FOR SAFE OPERATION**

---

- 1) Make sure you are using the proper power (120V/60Hz, 220V/50Hz or 240V/50Hz) as stated on the name plate at the back of the typewriter.
- 2) Your typewriter is a highly sophisticated mechanism. Never attempt to repair it yourself. If repair becomes necessary, take it to the nearest authorized service center.
- 3) Never insert metal objects such as a screwdriver, paper clip, nail file, etc., inside the typewriter. This could cause damage to the typewriter and/or electrical shock.
- 4) Do not leave your typewriter unattended when it is turned on. Always turn off the typewriter when you have finished typing.
- 5) Dust the typewriter lightly, using only a dry cloth. Never use water or solvents such as thinner, alcohol, etc., to clean your typewriter.
- 6) Be sure to turn off the typewriter when you need to open the top cover for changing accessories.

# PART NAMES AND FUNCTIONS

## 1. Operating parts

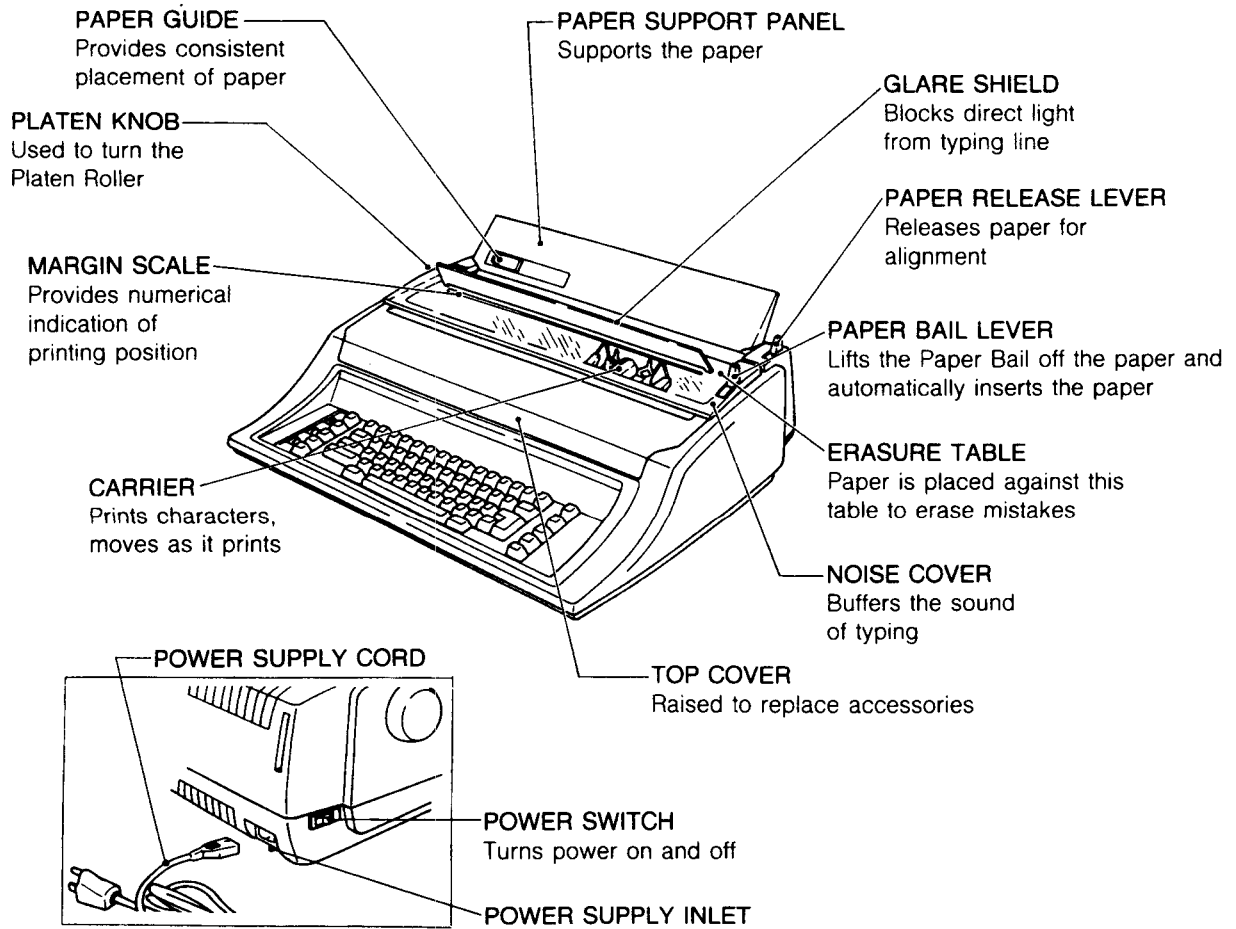

## 2. Carrier mechanism (under the top cover)

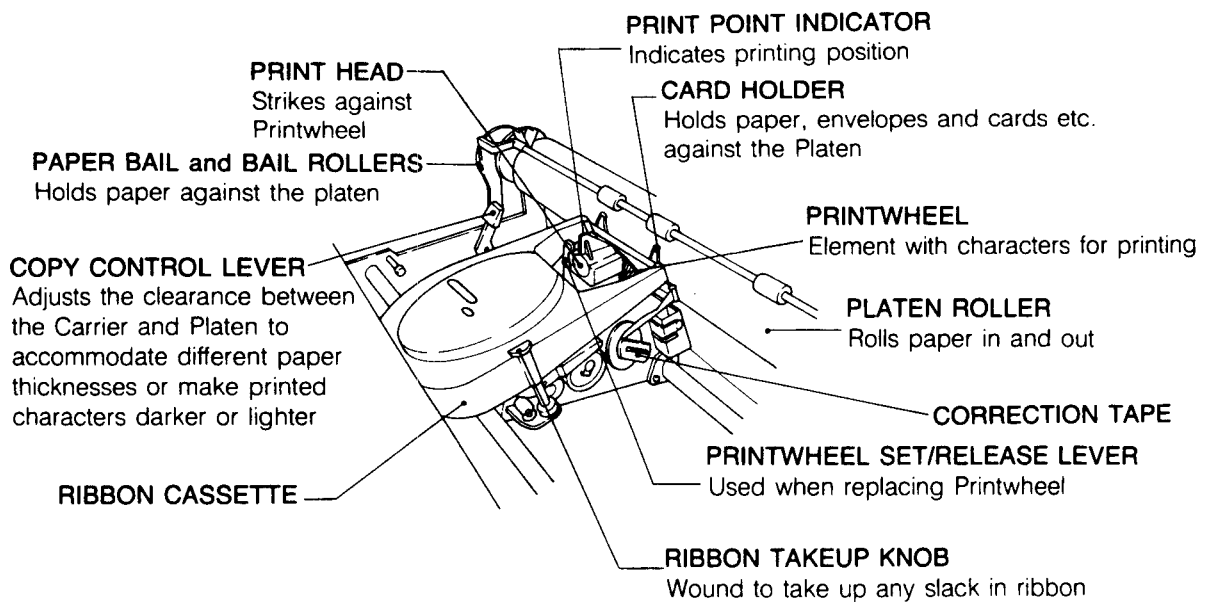

— German Keyboard —

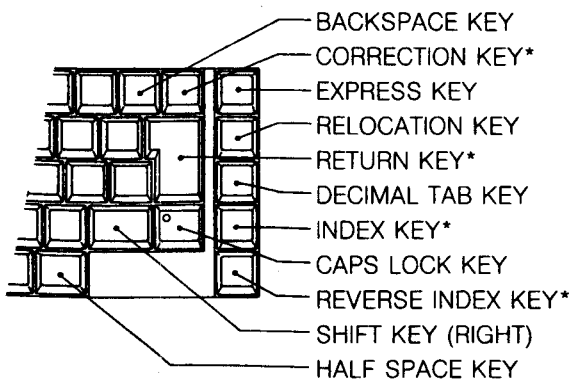
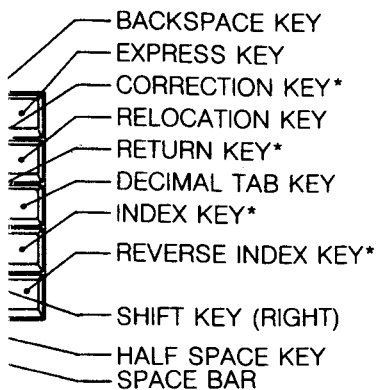

\*Hold down these keys repeat action.

**BACKSPACE KEY**

Light touch moves the Carrier backward one space. repeat action, hold it down.

**CORRECTION KEY** (see page 12 for details)  
 Erases characters.

**RETURN KEY**

Advance paper one line and return the Carrier to left margin, press the Return Key.

**EXPRESS KEY**

Press to return the Carrier to the left margin without spacing.

**RELOCATION KEY**

If the character(s) corrected were within 66 lines with single spacing, 40 lines with one-and-a-half line spacing and 33 lines with double spacing, you can return the Print Point Indicator to the location after the last character typed by pressing the Relocation Key.

**DECIMAL TAB KEY** (see page 14 for details)

Automatically aligns all numbers by their decimal points.

**INDEX KEY**

Press to advance paper without moving the Carrier. Paper will advance a half-line (1/12") every time the key is pressed. By holding down the key, paper will advance continuously.

**REVERSE INDEX KEY**

Press to retract paper without moving the Carrier. Paper will advance a half-line (1/12") every time the key is pressed. By holding down the key, paper will retract continuously.

### 3. Keyboard layout

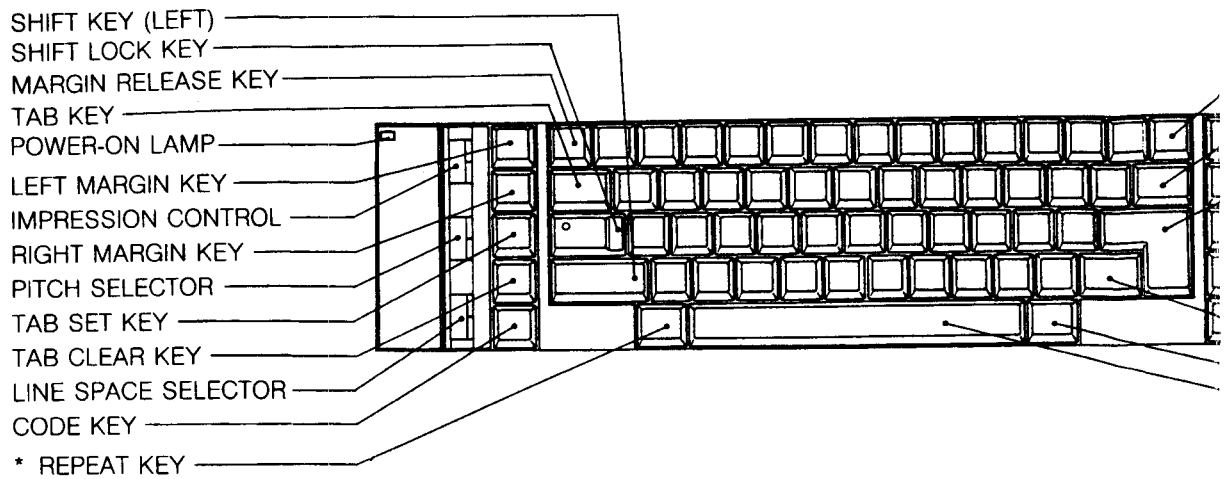

### 4. Key functions

<b>LEFT MARGIN KEY</b> (see page 9 for details) Sets the left margin.
<b>RIGHT MARGIN KEY</b> (see page 9 for details) Sets the right margin.
<b>TAB SET KEY</b> (see page 11 for details) Sets tabs.
<b>TAB CLEAR KEY</b> (see page 11 for details) Clears tabs.
<b>CODE KEY</b> Hold down the Code Key to print the upper right character of three character keys. Also hold down the Code Key to activate special functions (Auto Center, etc.) in conjunction with several other keys.
<b>MARGIN RELEASE KEY</b> (see page 9 for details) Releases the margins to type beyond them or set new ones.
<b>TAB KEY</b> (see page 11 for details) Moves the Carrier to the next tab.
<b>SHIFT LOCK KEY</b> Press to lock the Shift Key in position to type a series of capital letters. When it's locked, the Shift Lock Key Lamp lights up. Release it by touching either Shift Key.

<b>SHIFT KEY</b> Press and hold down to type capital letters or a character on the upper half of a key.
<b>REPEAT KEY</b> Press the Repeat Key after typing a character you want to repeat. This repeat action continues automatically until the Repeat Key is released or you reach the right margin or maximum limit. Such functions as Spacing, Backspacing, Return (line spacing) and Correction also repeat when the Repeat Key is pressed after them.
<b>SPACE BAR</b> A light touch moves the Carrier ahead one space. For repeat spacing, hold it down.
<b>HALF SPACE KEY</b> Press to move the Print Point Indicator one half space to the right. This key is useful for inserting or deleting characters in between text on paper.

<b>BAC</b> A lig For
<b>COF</b> Corr
<b>RE</b> To a the
<b>EXP</b> Pre: line



# **BASIC OPERATION**

## **1. HOW TO START TYPING**

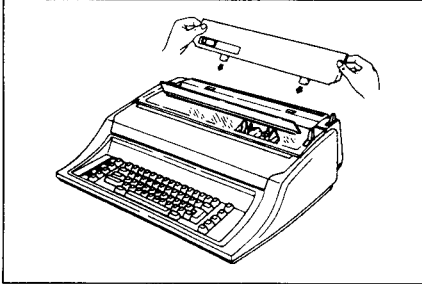

### **1. Set up typewriter**

- 1) Insert the Paper Support Panel.

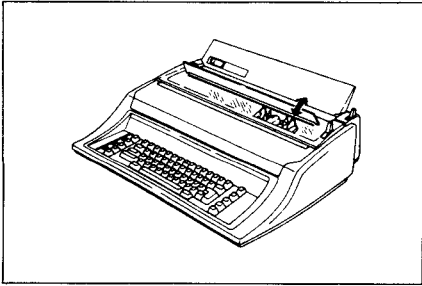

- 2) Position the Glare Shield to prevent direct light from obscuring the typing line.

- If this is the first time you have used this machine, be sure to release the Carrier before any operation by following the unpacking instructions.
- The Carrier is locked in position during transportation by the Carrier Protectors. If the power is turned on before releasing the Carrier, repeating beeps will sound. Immediately turn off power and remove the Carrier Protectors.

### **2. Turn on typewriter**

- 1) Plug one end of the Power Supply Cord into the machine and the other end into a standard outlet of the voltage/ frequency specified on the name plate.

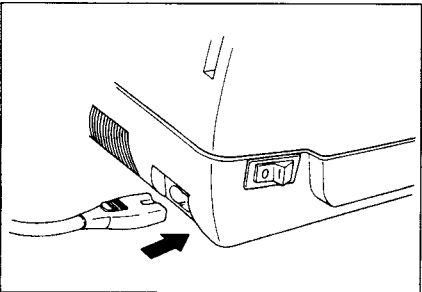

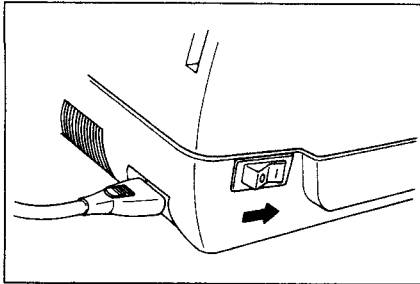

2) Turn on the Power Switch located at the left rear of the typewriter. The following initial operations occur:

1. A beep sounds and the Power-on Lamp (green) on the keyboard lights up.
2. The Carrier moves to the extreme left side and then moves to the left margin. The Printwheel rotates and stops at the programmed position.

While the above operations are occurring, all other typewriter functions stop. Start the next operation only after the initial operations are completed.

- Make sure the Printwheel, Ribbon Cassette and Correction Tape are properly installed.

### 3. Insert paper

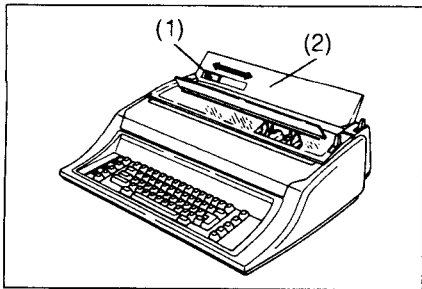

- 1) Move the Paper Guide (1) on the Paper Support Panel (2) to the desired position to assure consistent placement of paper. Normally, set the Paper Guide (1) at the 8-1/2" mark (for 8-1/2" width paper).

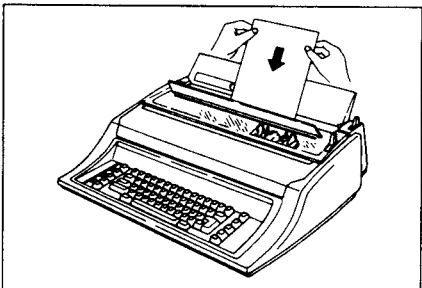

- 2) Insert paper against the Paper Guide.

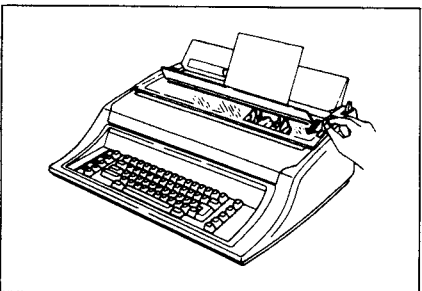

- 3) Pull the Paper Bail lever toward you as far as it will go. The Carrier advances to the position 40 on the margin scale (in 10 pitch) and the Platen rotates to automatically insert the paper to a position one inch from the top of the page. The Carrier will then return to the left margin.

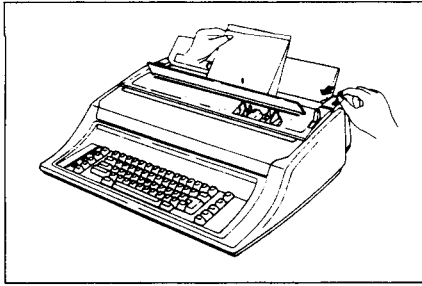

- 4) Pull the Paper Release Lever toward you, to straighten the paper.
- 5) Return the Paper Release Lever and Paper Bail Lever to the rear before typing.

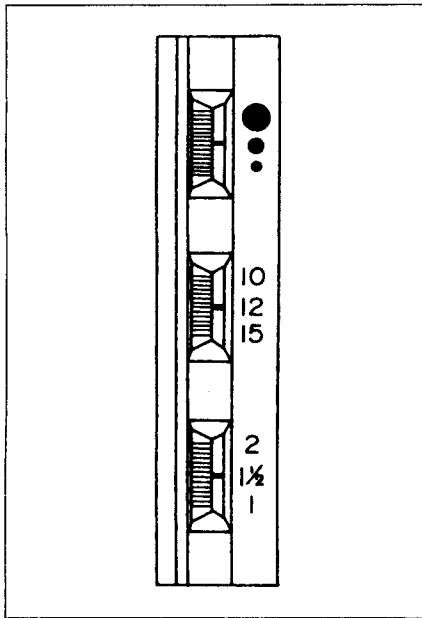

#### 4. Set typing control

- 1) Impression Control  
Print impression may vary depending on the voltage supply, the type of Printwheel, Ribbon, paper being used, or the number of carbon copies being made. Adjust this control for best print quality. The largest dot represents the heaviest impact.
- 2) Pitch Selector  
The Pitch Selector should be set to match the Printwheel being used. Typing can be done with different pitches on the same line.  
10: PICA pitch – 10 characters per inch  
12: ELITE pitch – 12 characters per inch  
15: MICRON pitch – 15 characters per inch
- 3) Line Space Selector  
Setting 2 provides double spacing (3 lines per inch).  
Setting 1-1/2 provides one-and-a-half spacing (4 lines per inch).  
Setting 1 provides single spacing (6 lines per inch).

#### 5. Ribbon cassette selection

Correctable Ribbon Cassettes and Multi-strike Ribbon Cassettes can be used with this typewriter.

##### When a correctable ribbon cassette is used:

Hold down the Code Key and press the third key to the left of the Right Shift Key. A beep sounds, indicating that the correctable ribbon setting has been made.

##### When a multi-strike ribbon cassette is used:

Hold down the Code Key and press the second key to the left of the Right Shift Key. A beep sounds, indicating that the multi-strike ribbon setting has been made.

The typewriter has been set to use correctable ribbon when it is shipped. Select the proper ribbon setting when changing cassettes.

- This setting is protected by the back-up battery when power is turned off.
- If the proper setting is not selected, it will result in poor print quality or wasted ribbon (since the ribbon feed differs according to ribbon type.)

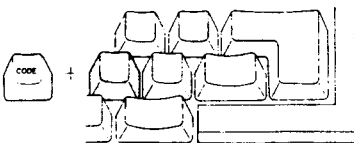
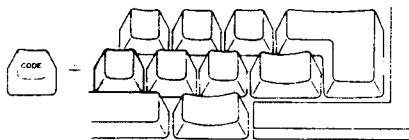

## 2. MARGINS

### 1. Auto margins (Standard pre-set margins)

The following auto margins are permanently stored in this typewriter.

	Left Margin	Right Margin
PICA typing (10 pitch)	20	85
ELITE typing (12 pitch)	24	102
MICRON typing (15 pitch)	30	128

When the power is first turned on, the Print Point indicator moves to the left margin. A beep sounds 5 spaces before the right margin to remind you that the Print Point Indicator is nearing the right margin. A second beep sounds when the Print Point Indicator reaches the right margin.

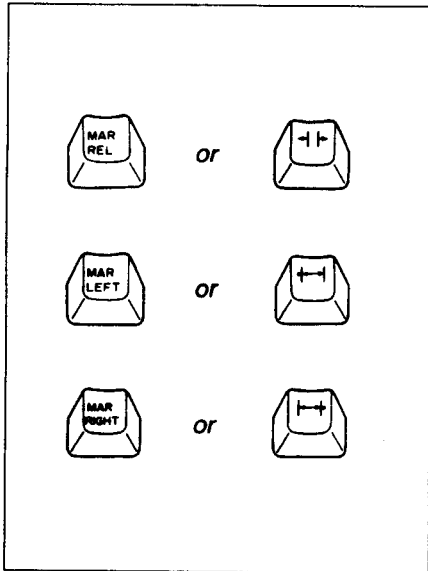

### 2. Setting new margins

- 1) Move the Print Point Indicator to the position where you want to set a new margin by using the Space Bar and/or Backspace Key.
  - To set a new margin beyond either of the present margins, press the Margin Release Key while the Print Point Indicator is at that margin, then move the Print Point Indicator to the desired position.
- 2) Press the Left or Right Margin Set Key to set the new margin. A beep will signal it has been set. When you set a new left or right margin, the respective auto margin is automatically cleared.
  - The left and right margins must be at least one inch apart. Obviously, a left margin cannot be set to the right of the right margin, or a right margin to the left of the left margin.

### **3. Typing beyond margins**

- 1) Typing beyond right margin  
Press the Margin Release Key when the Print Point Indicator stops at the right margin and continue typing.
- 2) Typing beyond left margin  
Press the Margin Release Key at the left margin, and press the Backspace Key to move the Print Point Indicator to the position where you want to start typing.

- Your typewriter has a memory back-up battery which retains the tab settings for a minimum of five years with the power switch off.
- Five beeps sound when power is turned on if the back-up battery is completely drained, and the tab settings are cleared. Please contact your nearest service center in this case.

### **4. Going beyond the right margin with auto return function activated**

When the Auto Return function is activated, you can go past the right margin by using the Tab Key; or by using the Space Bar on a line where nothing has been printed. (See page 16, "Automatic Carrier Return").

### 3. TABS

Setting tabs makes aligning columns or tables easy.

#### 1. Setting tabs

- 1) Move the Print Point Indicator to the position where you want a tab by using the Space Bar or Backspace Key.
- 2) Press the Tab Set Key. A beep sounds signaling that a tab has been set. A maximum of 30 tab stops can be set.

#### 2. Clearing tabs

- 1) Move the Print Point Indicator to the tab you want to clear.
- 2) Press the Tab Clear Key. A beep will confirm that the tab has been cleared.

- If you want to clear all tabs, first press the Tab Clear Key at any position, then press the Repeat Key. A beep will confirm that all tabs have been cleared.

#### 3. Using tabs

Press the Tab Key to advance the Print Point Indicator to the next tab on the right.

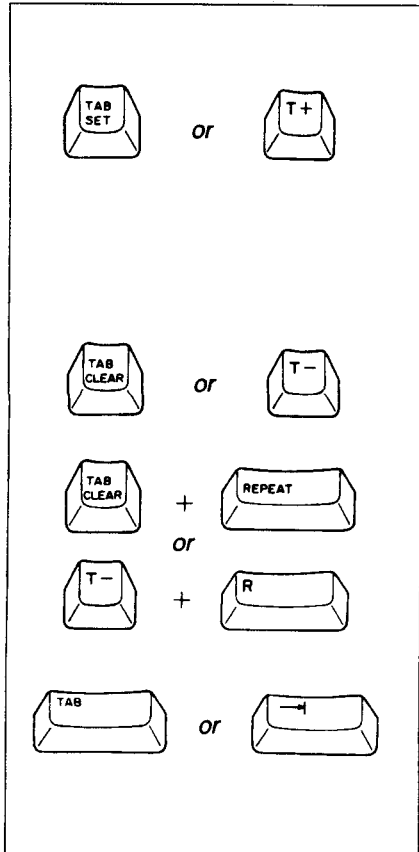

## 4. CORRECTIONS

Your new typewriter has a 250-character automatic correction memory. The machine remembers up to 250 characters typed in the last five lines (single spacing), thereby allowing you to correct any or all of them. (For one-and-a-half line spacing, 4 lines and double spacing, 3 lines).

Characters beyond the correction memory can also be corrected easily with a few extra steps.

### 1. Correcting any or all of the last 250 characters in the last five lines

- 1) Press the Correction Key. The Print Point Indicator will backspace and erase the incorrect character(s).

- If you hold down the Correction Key, the machine will continue erasing characters in the correction memory range line until the Correction Key is released.

- 2) Type the correct character(s).

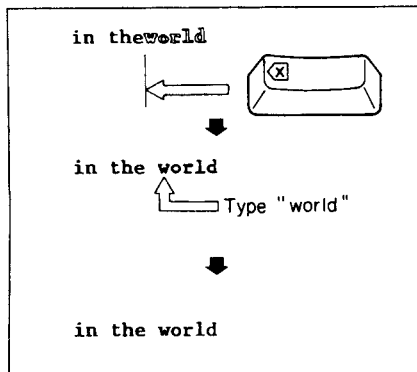

### 2. Correcting previous character(s) within the correction memory

- 1) Using the Reverse Index Key, the Space Bar, and/or the Backspace Key, align the Print Point Indicator with the character(s) to be corrected.

- 2) Press the Correction Key to erase the incorrect character(s).

- Hold down the Correction Key to correct more than one character. Correction will be repeated until the Correction Key is released.

- 3) Type the correct character(s).

- 4) Press the Relocation Key to return the Print Point Indicator to its previous position.

- The correction memory is cleared if the power is shut off.

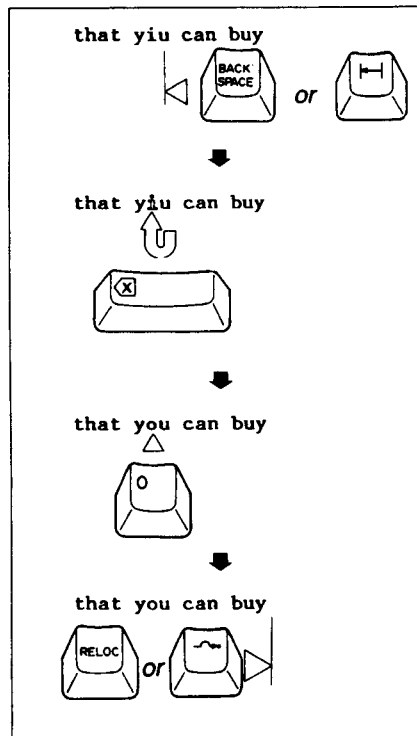

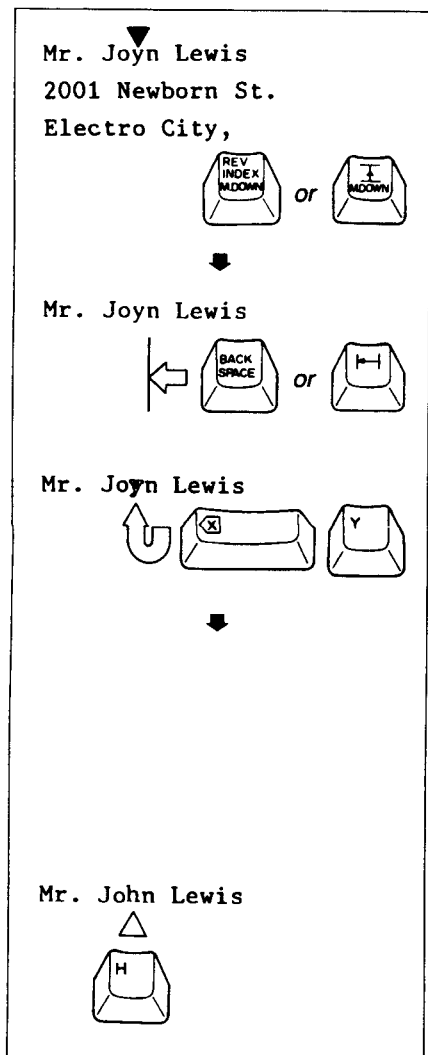

### 3. Correcting character(s) outside the correction memory/Manual correction

- 1) Press the Reverse Index or Index Key to position the Print Point Indicator on the line where the correction is to be made. Do not use the platen knob to do this.
- 2) Position the Print Point Indicator one space to the right of the character(s) to be corrected, using the Space Bar and/or Backspace Key.
- 3) Press the Correction Key. The Print Point Indicator will backspace to the incorrect character. Type the incorrect character and it will be erased. The Print Point Indicator will not move.

#### ■ Manual correction

If the Print Point Indicator is already aligned at the character to be corrected, hold down the Code Key and press the Correction Key. (The character will be erased but the Print Point Indicator will not move.) Then type the incorrect character.

- 4) Type the correct character(s).
- 5) Return the Print Point Indicator to the previous position.



# SPECIAL FUNCTIONS

## 1. DECIMAL TABULATION

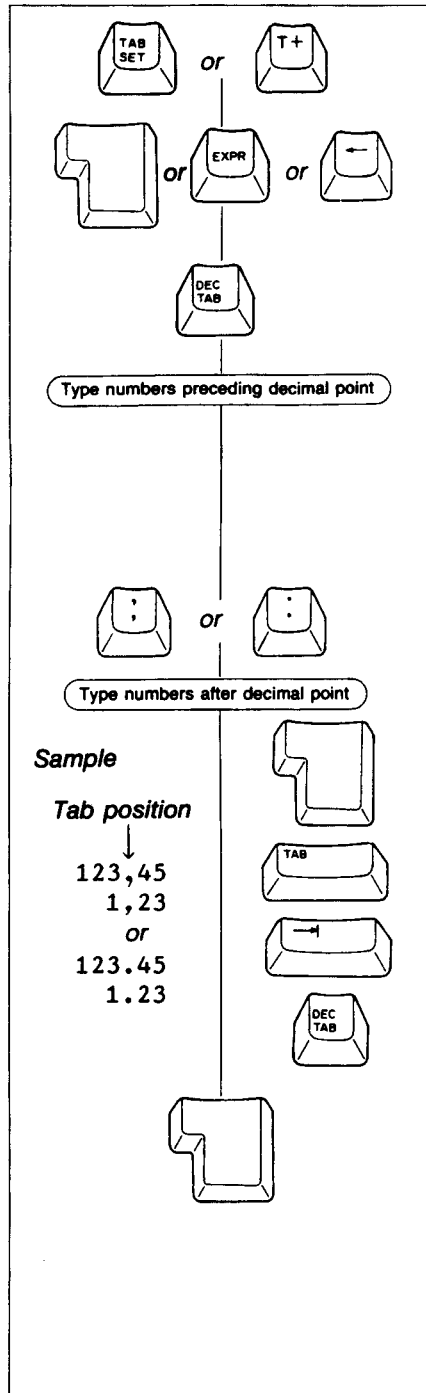

This function allows you to type statistical text easily. All numbers are automatically aligned by their decimal points.

- 1) Set tab(s) at the decimal positions for each column.
- 2) Press the Return Key or Express Key to return the Carrier to the left margin.
- 3) Press the Decimal Tab Key. The Print Point Indicator will move to the first tab stop.
- 4) Type the numbers preceding the decimal point. The Print Point Indicator moves one space to the left for each number typed. (Nothing is printed at this time.)
  - If you make a mistake, press the Correction Key to cancel all text (numbers) typed. The Print Point Indicator returns to the tab position. Then retype the number.
- 5) Type the decimal point (Comma or Period Key). The number will be automatically printed with a decimal point. The decimal tab mode is automatically cleared. Type the numbers after the decimal point.
  - When typing numbers without decimal points or words, you have 3 options to print the numbers/words.
    - a) Press the Return Key. The number will be printed and the Carrier will stay there.
    - b) Press the Tab Key. The text (number) will be printed and the carrier will advance to the next tab position.
    - c) Press the Decimal Tab Key. The text (number) will be printed and the carrier will advance to the next tab, making it a decimal tab again.
- 6) To advance to the next line, press the Return Key and repeat steps 3) through 5).
  - To cancel the Decimal Tab function after it has been activated, press the Correction/Return Keys as follows. Two beeps sound and this function is cancelled.
    - a) If some characters have been typed, first press the Correction Key to clear the text. Then press either the Correction or Return Key.
    - b) If no characters have been typed, press either the Correction or Return Key.

## 2. AUTOMATIC CENTERING

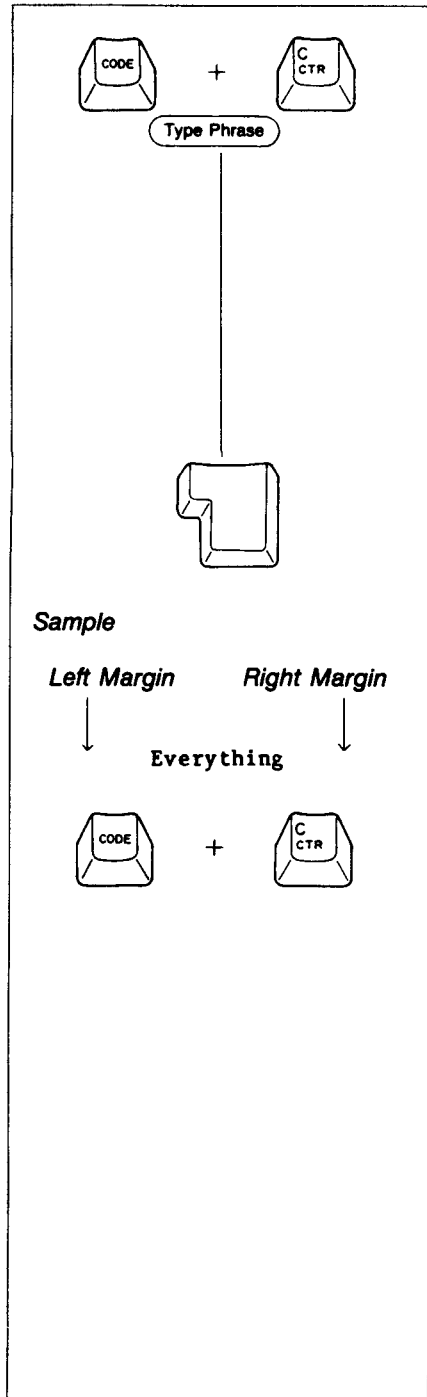

This function allows you to center text evenly between the left margin (or indent position) and the right margin.

- 1) Hold down the Code Key and press the "C" Key. The Print Point Indicator automatically advances to the center of the left (indent) and right margins.
- 2) Type the phrase to be centered. The Print Point Indicator moves back to the left as characters are typed. (Nothing is printed at this time.)
  - If you make a mistake, press the Correction Key to cancel all text typed. The Print Point Indicator returns to the center of the left (indent) and right margins.
  - If more characters are typed than will fit between the left (indent) and right margins, the Carrier will stop at the left margin and a beep will sound. Press the Margin Release Key to continue typing.
- 3) Press the Return Key. The text is printed, centered between the left (indent) and right margins, and the Automatic Centering function is cleared. The Print Point Indicator remains positioned one space to the right of the centered text.

- If you hold down the Code Key and press the "C" Key to print the text centered, the carrier will automatically return and advance to the center on the next line. The Auto Centering function is still active.
- To cancel the Auto Centering function after it has been activated, press the Correction/Return Keys as follows. Two beeps sound and this function is cancelled.
  - a) If some characters have been typed, first press the Correction Key to clear the text. Then press either the Correction or Return Key.
  - b) If no characters have been typed, press either the Correction or Return Key once.

### 3. AUTOMATIC CARRIER RETURN

This function eliminates the need to press the Return Key at the end of every line.

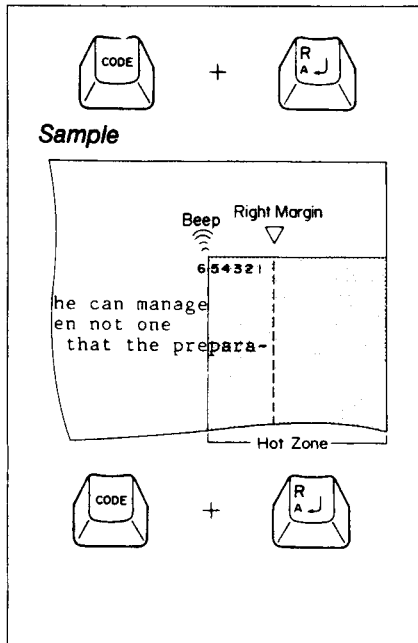

- 1) Hold down the Code Key and press the "R" Key. A beep sounds to signal that the function has been activated.
- 2) Once activated, a beep is heard when the Print Point Indicator enters the hot zone (five spaces to the left and anywhere to the right of the right margin). The Carrier will automatically return when you type a hyphen or space.
  - When you type two spaces in the hot zone (after a period), the second space is ignored to prevent a space from being made at the left margin when a sentence ends in the hot zone.
- 3) To terminate the Automatic Carrier Return function, hold down the Code Key and press the "R" Key again. Two beeps sound to signal that the function has been terminated, but the Carrier does not move.

### 4. REQUIRED HYPHEN AND REQUIRED SPACE

This function allows you to enter hyphens or spaces in the hot zone that will not trigger the automatic carrier return. (Normally the Carrier automatically returns after typing a hyphen or a space in the hot zone while Automatic Carrier Return is activated.)

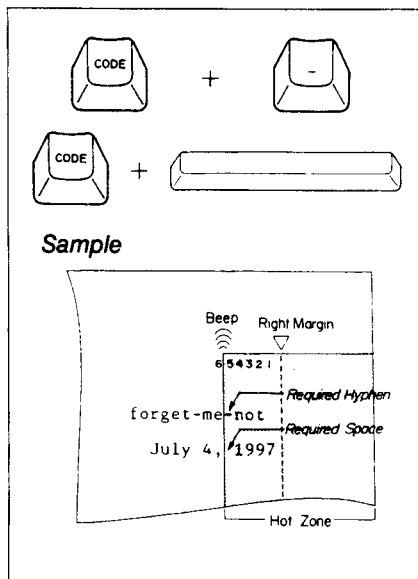

- 1) To type a required hyphen or required space, hold down the Code Key and the Hyphen Key or Space Bar.
- 2) A hyphen or space will be typed but the Carrier will not return.

## 5. AUTOMATIC PARAGRAPH INDENTATION

This function allows you to set a temporary left margin in order to indent an entire paragraph without tabbing or spacing after each carrier return.

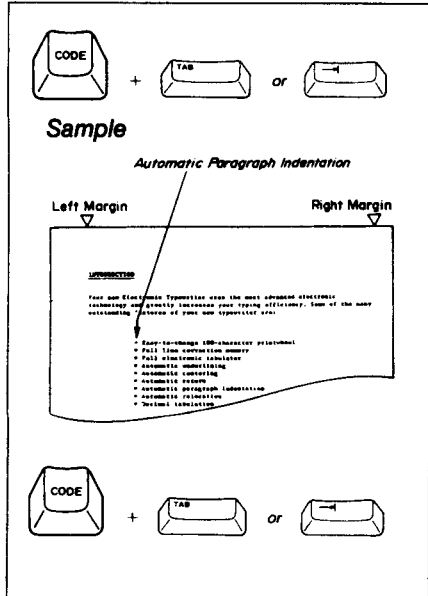

1) Hold down the Code Key and press the Tab Key. The Print Point Indicator will advance to the first tab setting and this becomes the temporary left margin until terminated.

- A tab must be set to activate this function. If no tabs have been set, this instruction will be ignored by the typewriter.

2) To terminate Paragraph Indentation, hold down the Code Key and press the Tab Key again. Two beeps sound to signal that the function has been terminated, but the Carrier does not move.

## 6. SECOND KEYBOARD (SPECIAL CHARACTER SET)

The symbols located at the upper right side of the three-character keys can be typed with the following procedure.

Hold down the Code Key and press the key with the desired symbol.

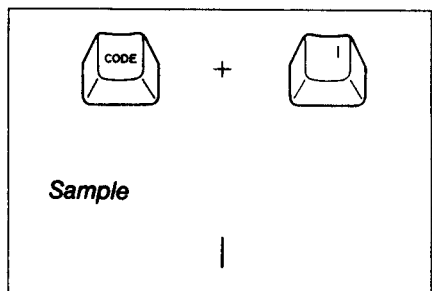

## 7. CAPS LOCK

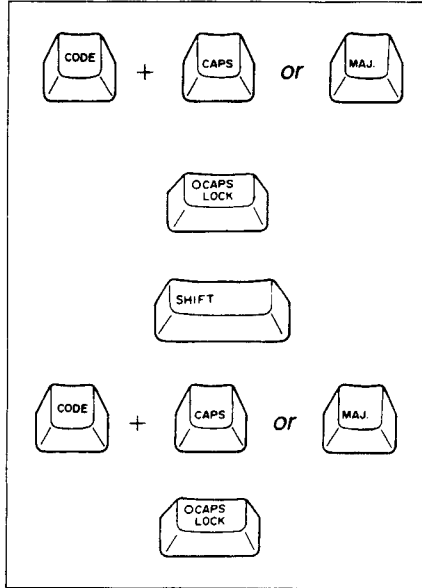

This function enables numbers and upper case alphabetic characters to be printed without shifting.

- 1) Hold down the Code Key and press the "CAPS/MAJ." Key.

### **Only for the German Keyboard.**

Press the Caps Lock Key, and the Caps Lock Key Lamp lights up.

- 2) While in Caps Lock mode, alphabetic characters are capitalized without pressing the Shift Key. The number/symbol keys are printed in lower case.
  - If you press the Shift Key in this mode, alphabetic characters are printed in lower case, and the number/symbol keys are printed in upper case.
- 3) To terminate, hold down the Code Key and press the "CAPS/MAJ." Key or press the Caps Lock Key again. All characters are printed normally.

## 8. MICRO UP/MICRO DOWN

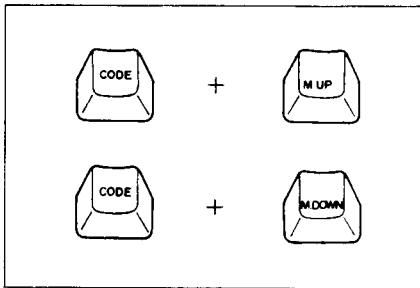

This function allows you to align the Print Point Indicator for correcting something previously typed or on a printed form.

- 1) Hold down the Code Key and press the Index Key to advance paper 1/16 line (1/96 inch) at a time.
- 2) Hold down the Code Key and press the Reverse Index Key to retract paper 1/16 line (1/96 inch) at a time.

## 9. AUTOMATIC UNDERLINING

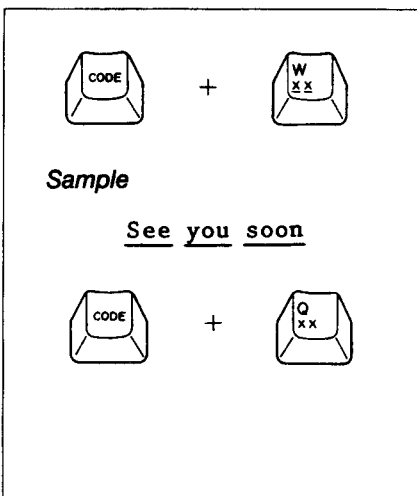
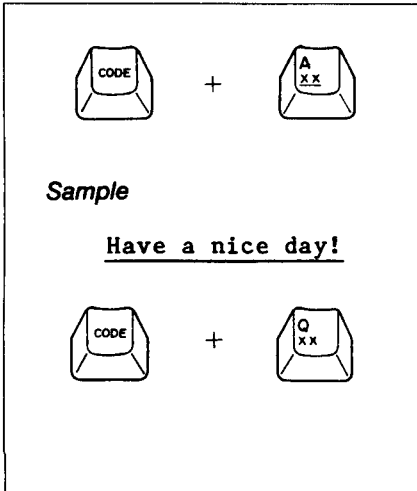

### 1. Automatic full underlining

This function allows for simultaneous underlining of all text and spaces.

- 1) Hold down the Code Key and press the "A" Key. A beep sounds to signal the function has been activated.
- 2) Type in the text to be underlined.
- 3) To terminate Full Underlining, hold down the Code Key and press the "Q" Key. Two beeps sound to indicate the function has been terminated.

### 2. Automatic word underlining

This function allows for simultaneous underlining of all words (all text except spaces).

- 1) Hold down the Code Key and press the "W" Key. A beep sounds to signal the function has been activated.
- 2) Type in the text to be underlined.
- 3) To terminate Word Underlining, hold down the Code Key and press the "Q" Key. Two beeps sound to indicate the function has been terminated.

## 10. BOLD TYPING

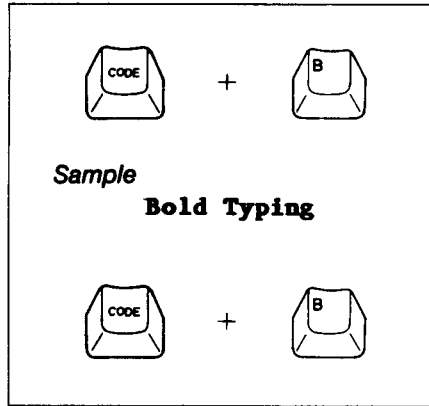

This function makes words stand out from the rest of the text. It's useful for emphasizing titles, critical information, etc.

- 1) Hold down the Code Key and press the "B" Key. A beep sounds to signal that the Bold Typing has been activated.
- 2) Type in the text.
- 3) To terminate Bold Typing, hold down the Code Key and press the "B" Key again. Two beeps sound to signal that the Bold Typing has been terminated.

## 11. FRAMING

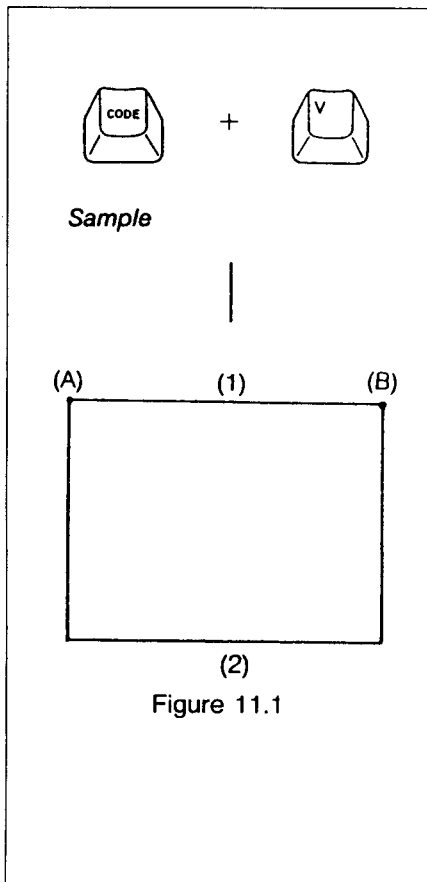

This function permits you to make vertical lines to enclose figures or text in a table. (Full framing can be achieved in combination with the Underline function.)

- 1) Hold down the Code Key and press the "V" Key. A vertical (|) line is printed. The Print Point Indicator does not move.
  - When this sequence is activated a second time, the platen advances one line space, and a vertical line is printed in the same print position.
  - If both keys are pressed and held, the typewriter will continue printing vertical lines until both keys are released.
- 2) To completely enclose text, create the top and bottom lines of the frame using the Underline Key. (1 and 2 in the Figure 11.1)
  - Setting margins at the desired width makes it easier to type underlines of the same length.
- 3) Next, position the Print Point Indicator to one line below position "A" in Figure 11.1. Backspace once, then press the Half Space Key.
- 4) Hold down the Code Key and press the "V" Key until the two lines (1 and 2) are joined.
- 5) Next, position the Print Point Indicator to one line below position "B" in Figure 11.1. Press the Half Space Key once.
- 6) Hold down the Code Key and press the "V" Key until the two lines (1 and 2) are joined on the right side.

# 12. FORMAT (MARGIN AND TAB) MEMORY

This function enables up to 3 different formats (margin and tab settings) to be stored in the memory.

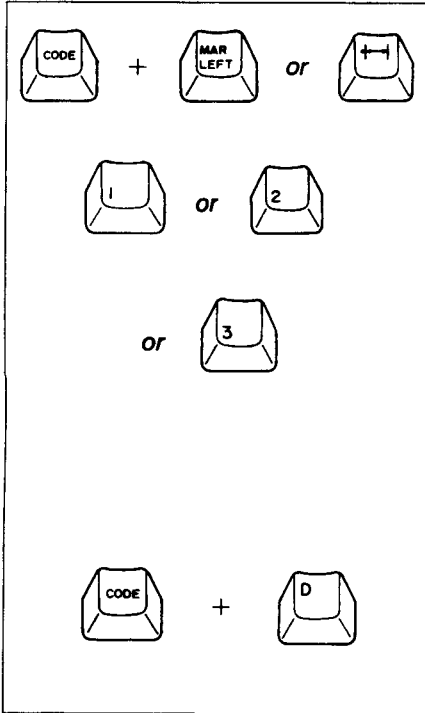

## 1. Storing

- 1) Set the desired margins and tabs.
- 2) Hold down the Code Key and press the Left Margin Key. One beep will sound and the Shift Lock Key Lamp begins to blink.
  - To cancel this function before storing, hold down the Code Key and press the Left Margin Key. Two beeps will sound and the Shift Lock Key Lamp goes out.
- 3) To store the margins and tab (format) settings, press the "1", "2" or "3" Key. One beep sounds and the Shift Lock Key Lamp goes out, indicating the format has been stored under the respective key.
  - If a format has been previously stored under the key selected, it will be cancelled and replaced with the new format.
- 4) To cancel all stored formats, hold down the Code Key and press the "D" Key during storing/recalling of the format. Three beeps sound.

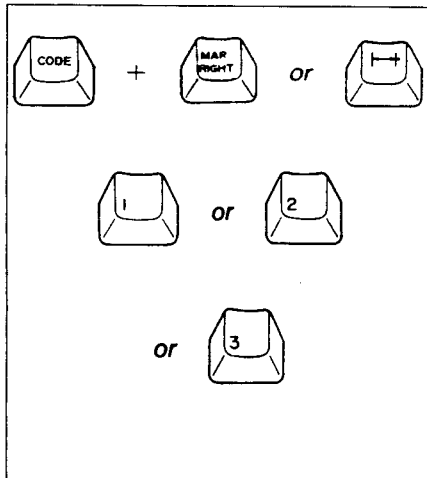

## 2. Recall

- 1) Hold down the Code Key and press the Right Margin Key. One beep will sound and the Shift Lock Key Lamp begins to blink.
  - To cancel this function before recalling, hold down the Code Key and press the Right Margin Key again. Two beeps will sound indicating the function has been cancelled.
- 2) Press the key under which the desired format is stored (1, 2 or 3). One beep sounds, the Shift Lock Key Lamp goes out, and the Print Point Indicator moves to the left margin set under that format.
  - If no beep is heard when the 1,2 or 3 Key is pressed, it indicates that no format is stored under that particular key.



# HOW TO CHANGE ACCESSORIES

## 1. RIBBON CASSETTE

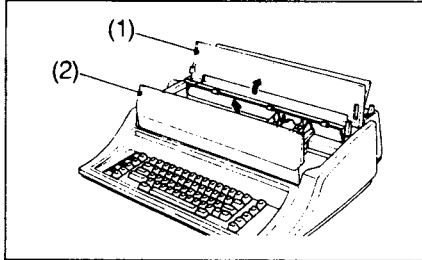

### 1. Removing ribbon cassette

- 1) Turn off the machine, and open the Noise Cover (1) and Top Cover.
- 2) Remove the Ribbon Cassette (3) by pulling it up the Cassette.

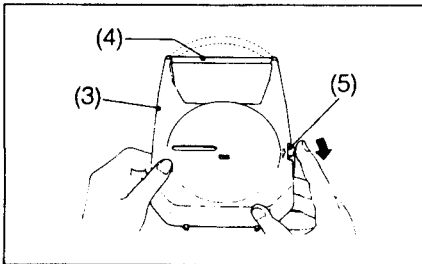

### 2. Installing ribbon cassette

- 1) Before installing the Ribbon Cassette (3), always take up any slack in the Ribbon (4) by winding the Ribbon Takeup Knob (5) clockwise.

- When installing a new ribbon, wind past the lead portion of the cassette.

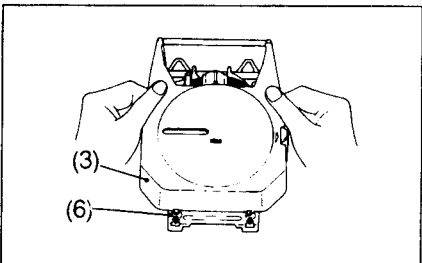

- 2) Fit the two Tabs at the back of the Ribbon Cassette (3) into the Ribbon Cassette Stand (6).

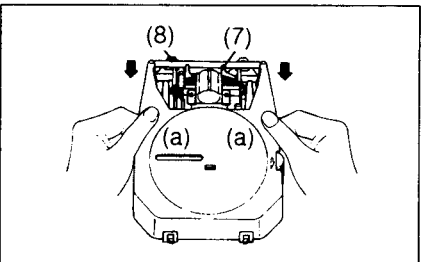

- 3) Carefully lower the front of the cassette so that the ribbon fits between the Ribbon Guides (7) and the Card Holder (8). Press the positions marked "a" in the illustration until the Ribbon Cassette snaps into place.

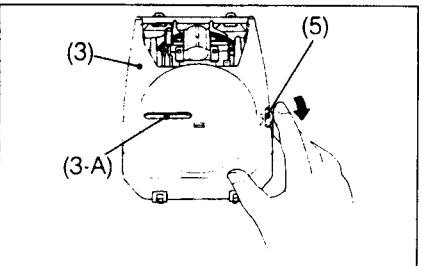

- 4) Turn the Ribbon Takeup Knob (5) to take up any slack that may have occurred when installing the Ribbon Cassette.

- 5) Lower the Top Cover (1) and Noise Cover (2).

- Before typing, verify the amount of remaining ribbon through the Cassette Window (3-A). Replace the Ribbon Cassette (3) if you see colored tape in the Cassette Window (3-A).

## 2. CORRECTION TAPE

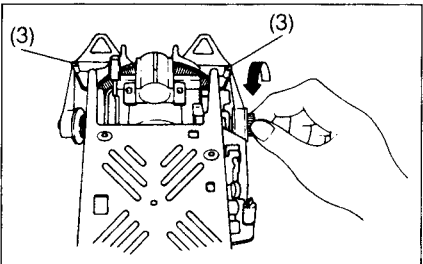
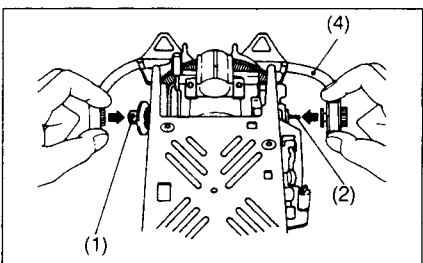
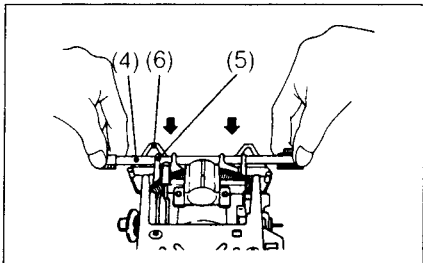
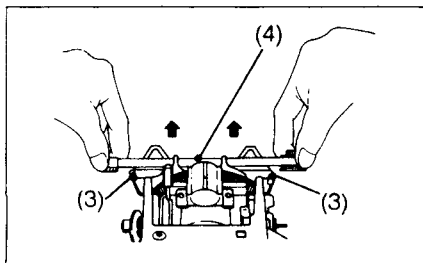
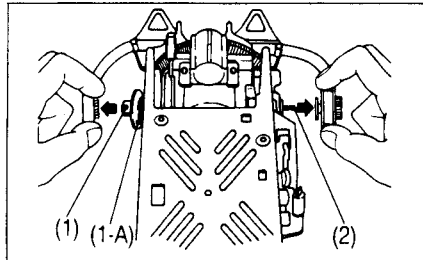

### 1. Removing correction tape

- 1) Turn off the machine. Open the Top Cover and remove the Ribbon Cassette as explained under "Removing ribbon cassette".
- 2) Remove the Left and Right Spools from the spindles (1), (2).
  - Be sure not to pull on the Spindle Hub (1-A) when removing the Left Spool.
- 3) Grasp both spools and bring back to a position that is parallel with the Guide Rollers (3). Pull on the Correction Tape (4) to take up any slack and lift it out of the typewriter.

### 2. Installing correction tape

- 1) Unwind the Correction Tape (4), holding the two spools in your hands. Carefully lower the Correction Tape (4) in between the Correction Tape Guides (5) and the Card Holder (6).
  - Make sure that the coated side of the Correction Tape (4) faces the platen.
- 2) Fit the full spool of Correction Tape (4) onto the Left (Supply) Spindle (1), and press the spool until it snaps into place. Then fit the right spool (the one with the knob) onto the Right (Takeup) Spindle (2).
- 3) Turn the right spool toward you until the colored portion of the tape disappears.
  - Check to make sure that the Correction Tape (4) has been fed properly behind the left and right Guide Roller (3).
- 4) Replace the Ribbon Cassette and close the Top Cover and Noise Cover.

### 3. PRINTWHEEL

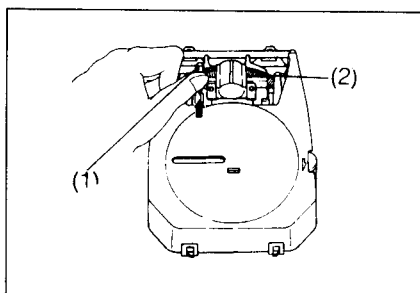
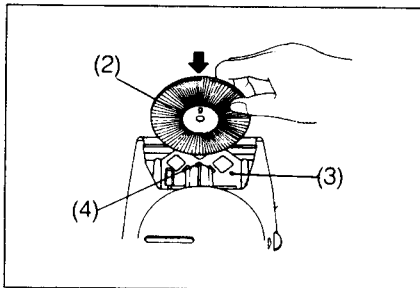
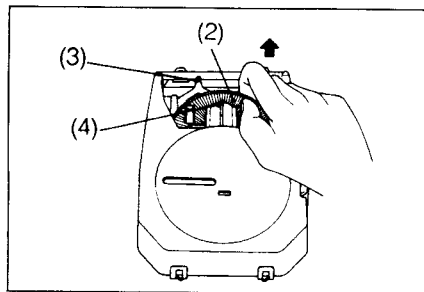
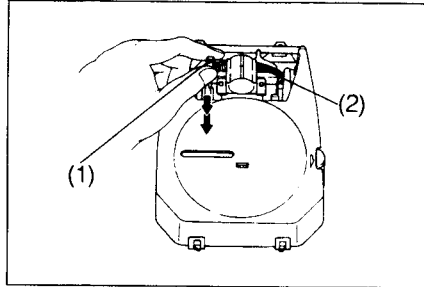

#### 1. Removing printwheel

- 1) Turn off the machine. Open the Noise Cover and Top Cover.
- 2) Pull the Printwheel Set/Release Lever (1) towards you and pull the lever again firmly.

- 3) Lightly grasp the top of the Printwheel (2) and carefully pull it up towards you.

- Be careful not to bend the top of the Ribbon Guides (3).

#### 2. Installing printwheel

- 1) Lightly grasp the edge of the Printwheel (2) and carefully lower it in between the Ribbon Guides (3) and Print Hammer (4).

- Make sure that the typeface (the side with typing style indicated) faces the platen.

- 2) Press the Printwheel Set/Release Lever (1) until it snaps into place, locking the mechanism.

- Press the Lever (1) as far as it goes again to make sure the Printwheel (2) has been locked into place.

- 3) Close the Top Cover and Noise Cover.

- Remount the Printwheel (2) if any abnormal noise is emitted or incorrect characters are printed.

---

# SUPPLIES

---

## 1. Printwheel

Your typewriter comes with a standard Printwheel. Besides this typestyle, a variety of Printwheels with different typestyles are available for your machine.

## 2. Ribbon cassette

### **Black Correctable Film Ribbon**

Your typewriter comes with Correctable Ribbon which provides excellent correction performance. This ribbon is not reusable because the carbon surface of the ribbon is transferred to the paper as you type.

### **Black Multi-Strike Film Ribbon**

This optional ribbon is not reusable but more characters can be typed at a lower cost.

- Make sure to select the proper ribbon setting when installing a new ribbon cassette.

#### **When a correctable ribbon cassette is used:**

Hold down the Code Key and press the third key to the left of the Right Shift Key. A beep sounds, indicating that the correctable ribbon setting has been made.

#### **When a multi-strike ribbon cassette is used:**

Hold down the Code Key and press the second key to the left of the Right Shift Key. A beep sounds, indicating that the multi-strike ribbon setting has been made.

## 3. Correction tape

### **Lift-Off Correction Tape**

Your typewriter comes with Lift-Off Correction Tape. This correction tape is used only with Correctable Ribbon which was originally installed on your typewriter. It lifts the black carbon ink off the paper.

### **Cover-Up Correction Tape**

This optional correction tape covers up the error and is used only with Multi-Strike Ribbon.

- Make sure that when you use a Ribbon Cassette with a Yellow Knob, use Correction Tape with Yellow Spools. When you use a Ribbon Cassette with a Blue Knob, use Correction Tape with Blue Spools.

---

# MAINTENANCE AND SERVICE

---

## 1. Cleaning

- Do not attempt to disassemble the typewriter to clean it.
- Dust the typewriter lightly, using only a dry cloth.
- Never use water or solvents such as thinner, alcohol, etc., to clean your typewriter.
- When the top cover is opened for replacement of the Printwheel, Ribbon Cassette or Correction Tape, be sure not to drop items such as pins, paper clips, nail files, etc., into the typewriter. They may result in damage.

## 2. Service

It is recommended that your typewriter be serviced at least once a year by a qualified service technician. Any malfunction caused by maintenance performed by anyone other than authorized service personnel will void the warranty.

If the typewriter fails to function or does not function properly, check the following:

- Is the typewriter plugged into a live socket?
- Is the power supply cord securely connected?
- Is the typewriter switched on?
- Is the printwheel properly installed?
- Are the ribbon cassette and the correction tape properly installed?
- Have the ribbon cassette or correction tape been used up?

If the typewriter still does not work properly after checking the above, contact an authorized service center.

### 3. Removing and assembling the platen

With this typewriter the Platen is removable. Remove the Platen as follows in the event of hard-to-clear jams or if the Platen becomes dirty.

Before starting, be sure to turn off the typewriter's Power Switch and unplug the Power Supply Cord.

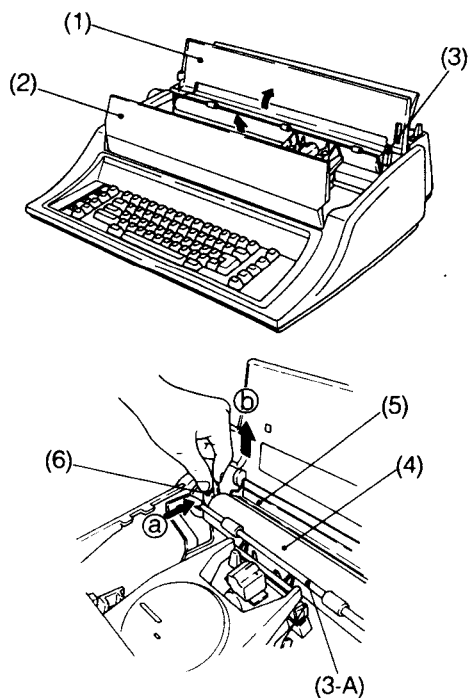

#### 1. Removing the platen

- 1) Open the Noise Cover (1) and the Top Cover (2). Pull the Paper Bail Lever (3) forward to bring the Paper Bail (3-A) away from the Platen (4). Move the Erasure Table (5) away from the Platen (4).
- 2) Push the Front Tabs (6) at both ends of the Platen (4) with both hands (a), then pick the Tabs (6) to disengage and lift the platen (4), (b).

#### 2. Assembly

Reverse the above procedure to reinstall the Platen.

#### Cleaning

Clean the platen by wiping it with a clean, dry cloth. If necessary, dampen the cloth with alcohol. (After wiping with alcohol, let the platen dry completely before reassembling.) Never clean with water or solvents; these liquids will damage platen's surface.

# OPTIONAL PARALLEL INTERFACE/ HOW TO USE AS A PRINTER

The parallel interface (Centronics compatible) your typewriter is equipped with enables you to print any data input on a computer equipped with this type of interfacing.

- All of the automatic printer function codes listed in this section are the same as \*Diablo 630 printer codes.
  - \* Diablo 630 software has some additional function codes which are not normally used such as: Graphics mode, Program mode, Download mode, etc., that are not included in the software for this typewriter (printer).
- \* Diablo is a trademark of Xerox corporation.

## 1. CONNECTION TO YOUR COMPUTER

Make sure the typewriter is turned off. Leaving the switch on may result in damage to the typewriter or computer.

Connect a parallel cable (with AMPHENOL 57-30360 connector or equivalent) of as short a length as possible to the typewriter and appropriate port in the host computer. Secure the cable with the clamp springs.

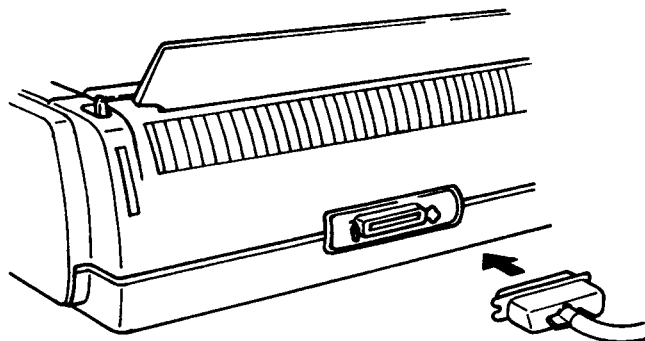

## 2. SET-UP MODES, PUT ON-LINE

Turn the typewriter Power switch on, set the Line space/Pitch selectors and Impression control to the desired settings. Also set any desired left and right margins and tabs. (All of these settings can be changed if you send instructions from your computer after it is On-line.)

Hold down the Code Key and press the "P" Key. Your typewriter is now in the Printer (On-line) mode, On-line with your computer.

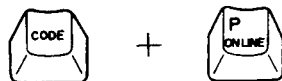

- Even if the optional parallel interface connector is not built into (installed in) your typewriter, when the Code Key is held down and the "P" Key pressed, the typewriter will go into the Printer (On-line) mode, and will not accept input from the keyboard.

To terminate the Printer (On-line) mode, hold down the Code Key and press the "P" Key again.

### Selecting Auto Line Feed

Depending on your computer, it may or may not send a line feed (LF) when it sends a carrier return (CR).

Hold down the Half Space Key and press the "5" Key to select CR=CR ONLY (factory setting).

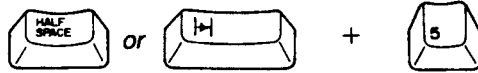

Hold down the Half Space Key and press the "4" Key to select CR=CR + LF.

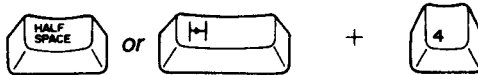

- If you select the CR=CR + LF mode for a computer which sends a line feed (LF) with a carrier return (CR), the typewriter will double the line feed. Conversely, if you select the CR=CR ONLY mode for a computer which does not send a line feed with a carrier return, the typewriter will not perform a line feed when the computer sends a carrier return, and lines will print on top of each other. Refer to the operation manual for your computer.

### Selecting the Page Length

Select the page length according to the standard paper size of the destination.

- In the USA and Canada, select "PAGE LENGTH 11 inch" (= 28cm). In most European countries, select "PAGE LENGTH 12 inch" (= 30cm).

Hold down the Half Space Key and press the "7" Key to select the 11 inch page length (factory) setting.

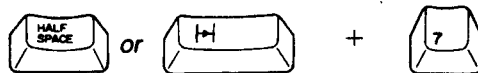

Hold down the Half Space Key and press the "8" Key to select the 12 inch page length setting.

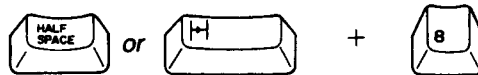

### Printout of The Set-up Mode Selections

In order to printout the present Set-up mode Selections, hold down the Half Space Key and press the "6" Key.

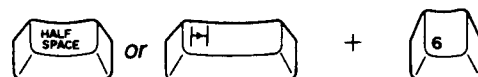

**Sample Printout** (factory setting)

ON-LINE MODE/CR=CR ONLY/11 INCH

### **Typewriter (Printer) Mode**

In the Printer (On-line) mode, the only input from the keyboard that is accepted is the Half Space Key + "4" Key or Half Space Key + "5" Key sequences which set Auto line feed, and the Half Space Key + "7" Key or Half Space Key + "8" Key sequences which set Page length, or a change in the Impression control setting to alter the printing impact.

Margins and tabs set in the Typewriter (Off-line) mode are valid in the Printer (On-line) mode, but can be changed with the respective Escape sequences. When the Half Space Key + "P" Key is pressed a second time, the typewriter goes to the Typewriter (Off-line) mode. When this happens, the margins/tabs set during the Printer (On-line) mode remain valid, but the settings on the keyboard for line spacing and horizontal spacing (typing pitch) are used.

The typewriter (printer) is initialized by holding down the Half Space Key and press the "R" Key, or with the ESC CR P or ESC SUB I sequences. This sets the margins at the extreme ends and clears all tabs, the Auto underline, Double strike and other such functions. The settings on the keyboard for line spacing and horizontal spacing (typing pitch) are used.

Turn on your computer. Be sure to read the operation manual for your computer and the balance of this manual to understand how they will work together.

## **3. CHARACTER TABLE AND CONTROL CODE**

### **Introduction**

In the Printer (On-line) mode, the typewriter (printer) receives codes from the computer and performs the corresponding functions. The codes include those for the 100 characters shown in the IBM and USA standard character tables as well as the special printing functions such as underlining and formatting.

Many of these functions can be used by your computer without any changes being made. If changes are necessary, use the special program most word processing programs include. Often given a name such as "INSTALL" or "INSTALLATION", this program allows the use of the special functions featured on your typewriter (printer). Check the manual supplied with your computer for more detail.

- Although it is essentially the same language, BASIC does have variations. For example, "PRINT # 1" and "LPRINT" are two variations of the command to output text to the printer. Consult your BASIC manual for the correct syntax for your system.



### Transmission of Characters

The following are examples of codes for the printing of the letter "A". Any one of the three coding methods can be used for character transmission to your typewriter (printer).

Enclosure of the character in quotation marks (in which case the computer computes the code automatically):

LPRINT "A" ..... Character data

The use of either decimal or hexadecimal coding:

LPRINT CHR\$(65) ..... Decimal data

LPRINT CHR\$(&H41) ..... Hexadecimal data

In programming, any of the printable characters shown in the character tables can be printed using the above methods.

### Printer Control Codes and Escape Sequences

Control codes are used to control the formatting, printing, carrier movements, paper feed and other functions of the typewriter (printer) when it is On-line. The control codes are often combined to form a sequence of two or more codes, beginning with the ESC code. The ESC code informs the typewriter during printing that the codes following it are special function codes even though the value of the code may be the same as a character code.

Either decimal or hexadecimal values may be used for the codes. In the following escape sequences, one uses a decimal value and the other a hexadecimal value for the ESC code. The second value in each sequence represents the letter "E" which, in an escape sequence, has the special function of activating the Underline mode.

This and other escape sequences are listed in the control code table.

LPRINT CHR\$(27); CHR\$(69) ..... Decimal data

LPRINT CHR\$(&H1B); CHR\$(&45) ..... Hexadecimal data

**Standard Character Table (printout with USA standard printwheel)**

	Binary	0000	0001	0010	0011	0100	0101	0110	0111
Binary	Hex	0	1	2	3	4	5	6	7
0000	0	NUL		SP		@	P	3	p
0001	1		DC1	!		A	Q	a	q
0010	2			"		B	R	b	r
0011	3		DC3	#		C	S	c	s
0100	4			\$		D	T	d	t
0101	5			%		E	U	e	u
0110	6			&		F	V	f	v
0111	7	BEL		'		G	W	g	w
1000	8	BS		(		H	X	h	x
1001	9	HT		)		I	Y	i	y
1010	A	LF	SUB	*	:	J	Z	j	z
1011	B		ESC	+	;	K	[	k	¼
1100	C	FF		,	<	L		l	
1101	D	CR		-	=	M	]	m	½
1110	E		RS	.	>	N		n	¾
1111	F		US	/	?	O		o	

On the machines with Hispano or Canada-French keyboard, the following codes print the different characters below:

Hex.	3C	3E	40	5B	5C	5D	5E	60	7B	7C	7D	7E
Dec.	60	62	64	91	92	93	94	96	123	124	125	126
HISPANO									@			
CANADA-FRENCH	<	>	@	[		]						

**ESC Control Code:**

Character \ ESC control code	ESC 1/4	ESC 1/2	ESC H	ESC I	ESC J	ESC K
USA						
HISPANO						
CANADA-FRENCH						

▲ : For characters with this mark, the carrier does not move when they are printed (they are called "silent" characters).

Example for character A:

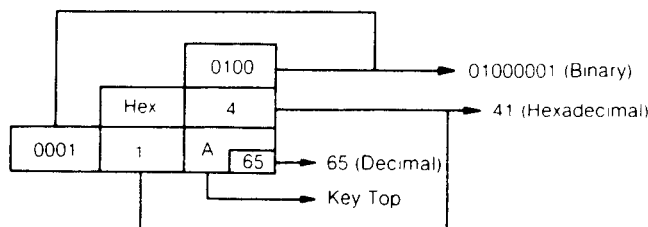

**IBM Character Table (ENGLISH)**

	Bi	0000	0001	0010	0011	0100	0101	0110	0111	1000	1001	1010	1011	1100	1101	1110	1111
Bi	Hex	0	1	2	3	4	5	6	7	8	9	A	B	C	D	E	F
0	0000	NUL		SP	0	@	P		p								
1	0001		DC1	!	1	A	Q	a	q								
2	0010			"	2	B	R	b	r								
3	0011		DC3	#	3	C	S	c	s								
4	0100			\$	4	D	T	d	t								
5	0101			%	5	E	U	e	u								
6	0110			&	6	F	V	f	v								
7	0111	BEL			7	G	W	g	w								
8	1000	BS		(	8	H	X	h	x								
9	1001	HT		)	9	I	Y	i	y								
A	1010	LF	SUB	:	J	Z	j	z									
B	1011		ESC	+	:	K	[	k				1/2					
C	1100	FF		.	<	L	]	l			E	1/4					
D	1101	CR		=	M	^	^	m									
E	1110			>	N	^	^	n									
F	1111			/	?	O	^	o									

Decimal: (27)(123) (27)(125) (27)(72) (27)(73) (27)(74) (27)(75)  
 ESC Control Code: ESC ESC ESC H ESC I ESC J ESC K  
 Character: 1/3 2/3 3/4 3

**International Character Table**

Hex.	Dec.	FRENCH	GERMAN	DUTCH	SWISS- G/F	SPANISH	NORWEGIAN	FINNISH	GREEK	ITALIAN	PORTUGUESE	DANISH
23	35	#	#			#		#	#		#	
3C	60	<	<	<		<	<	<	<		<	<
3E	62	>	>	>		>	>	>	>		>	>
40	64								@			
5B	91	[			[					[		
5D	93	]			]					]		
5E	94			^	^	^	^	^	^	^	^	^
60	96		^	^	^	^	^	^	^	^	^	^
7E	126			^								
7F	127										~	
80	128										Ç	
81	129	ü	u	ü	ü	ü	ü	ü	ü	ü	ü	ü
82	130	é	é	é	é	é	é	é	é	é	é	é
83	131	â		â	â	â	â		â	â	â	â
84	132	ä	ä	ä	ä	ä	ä	ä	ä	ä	ä	ä
85	133	à	à	à	à	à	à	à	à	à	à	à
86	134						ä	ä				ä
87	135	ç			ç	ç			ç	ç	ç	

Hex.	Dec.	FRENCH	GERMAN	DUTCH	SWISS- G/F	SPANISH	NORWEGIAN	FINNISH	GREEK	ITALIAN	PORTUGUESE	DANISH
88	136	ê		ê	ê	ê	ê		ê	ê	ê	ê
89	137	ë		ë	ë	ë	ë		ë	ë	ë	ë
8A	138	è	è	è	è	è	è	è	è	è	è	è
8B	139	ï		ï	ï	ï	ï		ï	ï	ï	ï
8C	140	î		î	î	î	î		î	î	î	î
8D	141		ï	ï	ï	ï	ï	ï	ï	ï	ï	ï
8E	142		Ä					Ä				
8F	143			Å			Å	Å				Å
91	145			æ			æ					æ
92	146			Æ			Æ					Æ
93	147	ô		ô	ô	ô	ô		ô	ô	ô	ô
94	148	ö	ö	ö	ö	ö	ö	ö	ö	ö	ö	ö
95	149		ò	ò	ò	ò	ò	ò	ò	ò	ò	ò
96	150	û		û	û	û	û		û	û	û	û
97	151	ù	ù	ù	ù	ù	ù	ù	ù	ù	ù	ù
98	152	ÿ		ÿ	ÿ	ÿ	ÿ		ÿ	ÿ	ÿ	ÿ
99	153		ö									
9A	154		ü									
9C	156	£		£	£		£		£	£		£
A0	160		á	á	á		á	á	á		á	á
A1	161		í	í	í		í	í	í		í	í
A2	162		ó	ó	ó		ó	ó	ó		ó	ó
A3	163		ú	ú	ú		ú	ú	ú			ú
A4	164					ñ					ñ	
A5	165					Ñ					Ñ	
A6	166					ä					ä	
A7	167					ö					ö	
A8	168					ç						
AB	171			½	½		½	½	½	½		½
AC	172			¼			¼	¼				
AD	173					ı						
E1	225		ß						ß			
E6	230		μ	μ								
ED	237			ø			ø					ø
F6	246											
F8	248	°	°	°	°					°		
FD	253		²	²			²	²	²		²	²
ESC (27)												
¼ (123)		§	§	ij	§	§	§	§	§	§	§	§
½ (125)		◇	³	³	Fr	∕	³	³	th	◇	³	³
H (72)		''	'▲	¾	''▲	''▲	''▲	¾	3	σ/ω	∕	''▲
I (73)			σ/ω	'▲	'▲	'▲	'▲	'▲	∕3	c/o	''▲	'▲
J (74)									''▲	''▲	'▲	ø
K (75)									'▲		~▲	%

▲ : For characters with this mark, the carrier does not move when they are printed (they are called "silent" characters.)

**Summary of Control Codes**

Control Codes	Dec	Hex	Function
NUL	0	0	Null
BEL	7	7	Sound bell
BS	8	8	Backspace (move back one space)
HT	9	9	Horizontal tabulation (move right to next tab)
LF	10	A	Line feed (go to next line)
FF	12	C	Form feed (go to top of next page)
CR	13	D	Carrier return (go to left margin)
DC1	17	11	Device control 1 (select printer)
DC3	19	13	Device control 3 (deselect printer)
ESC	27	1B	Escape (used for escape sequence code)
SP	32	20	Space (move one space right)
ESC 9	27 57	1B 39	Left margin set (at current position)
ESC 0	27 48	1B 30	Right margin set (at current position)
ESC S	27 83	1B 53	Control to slide switch
ESC E	27 69	1B 45	Full underline on (underline words and spaces)
ESC R	27 82	1B 52	Full underline off (cancel full underline)
ESC W	27 87	1B 57	Bold print on*
ESC O	27 79	1B 4F	Double strike on*
ESC &	27 38	1B 26	Bold print/double strike print off
ESC BS	27 8	1B 8	1/120 inch backspace
ESC 6	27 54	1B 36	Backward print on* (print from right to left)
ESC 5	27 53	1B 35	Backward print off (print from left to right)
ESC X	27 88	1B 58	Cancel some print mode (bold, double, underline, etc.)
ESC /	27 47	1B 2F	Bi-directional print on (forward & backward)
ESC \	27 92	1B 5C	Bi-directional print off (forward only)
ESC LF	27 10	1B A	Negative one line feed (go to previous line)
ESC U	27 85	1B 55	1/2 line feed (subscript)
ESC D	27 68	1B 44	Negative 1/2 line feed (superscript)
ESC RS n	27 30 n	1B 1E n	Line feed by (n-1)/48 inch (VMI)
ESC US n	27 31 n	1B 1F n	Horizontal space by (n-1)/120 inch (HMI)
ESC FF n	27 12 n	1B C n	Set page length to "n" line(s)
ESC HT n	27 9 n	1B 9 n	Absolute horizontal tab at position "n-1"
ESC 1	27 49	1B 31	Horizontal tab set (at current position)
ESC 2	27 50	1B 32	Clear all tabs
ESC 8	27 56	1B 38	Clear tab (at current position)
ESC 7	27 55	1B 37	Print suppression* (carrier moves but does not print)
ESC CR P	27 13 80	1B D 50	Initiate remote reset 1 (reset printer)
ESC SUB I	27 26 73	1B 1A 49	Initiate remote reset 2 (reset printer)

\* Automatically cleared with a CR (Carrier Return)

In addition to the above, all 100 characters on the printwheel, which is 6 more than the 94 specified by the USA or reference code tables, can be printed using the following escape code sequence:

Decimal:	(27)(123)	(27)(125)	(27)(72)	(27)(73)	(27)(74)	(27)(75)
ESC Control Code:	ESC ¼	ESC ½	ESC H	ESC I	ESC J	ESC K
USA Character:	£	¶	§	©	±	°

## 4. SPECIFICATIONS

Data communications : Asynchronous handshaking  
 Handshaking : By STROBE pulse (from computer), ACKNLG pulse and Busy signal (from typewriter (printer))  
 Logic level : TTL level (compatible with Centronics 8 bit parallel)

## 5. CONNECTOR PIN ASSIGNMENT

AMPHENOL 57-30360  
 (or equivalent)

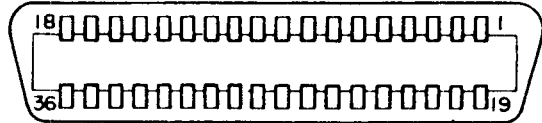

Signal Pin No.	Return Pin No.	Signal	Direction	Description
1	19	STROBE	In	STROBE pulse for reading data in with min. width of 0.5 $\mu$ s at receiving terminal
2	20	DATA 1	In	These signals give the 1st to the 8th bits of parallel data to the printer. They must be stable for 0.5 $\mu$ s before, after and during the STROBE pulse.
3	21	DATA 2	In	
4	22	DATA 3	In	
5	23	DATA 4	In	
6	24	DATA 5	In	
7	25	DATA 6	In	
8	26	DATA 7	In	
9	27	DATA 8	In	
10	28	ACKNLG	Out	Approx. 10 $\mu$ s handshaking pulse that tells the host computer that the printer has received data.
11		BUSY	Out	Handshaking signal that tells the host computer whether or not printer is busy. Data can be received when this signal is low, but cannot be received when the signal is high.
12		PE	Out	Paper empty warning-but tied to logic low as this typewriter is not equipped with a paper empty sensor.
13		SLCT	Out	This signal is always high.
14		NC	—	Not used/not connected
15		NC	—	Not used/not connected
16		+0V	—	Logic Ground Level
17		FG	—	Frame Ground (Chassis Ground)
18		+5V and/or NC	Out —	+5V power supply Not used/not connected
19 – 30		+0V	—	Logic Ground Level
31		INIT	In	Printer is initialized and printer buffer is cleared when this signal is low (min. pulse width 50 $\mu$ s)
32		ERROR	Out	This signal is always high.
33 – 36		NC	—	Not used/not connected

# 6. PARALLEL INTERFACE TIMING DIAGRAM

